

## **Chapter #2**

**EEE8013-3001**

### **State Space Analysis and Controller Design**

- **Introduction to state space**
- **Observability/Controllability**

## 1. Introduction

Assume that we have an  $n^{\text{th}}$  order system:  $x^{(n)} = f(x, x', x'', \dots, x^{(n-1)})$ . Very difficult to study it as even if it is a linear system we must solve an  $n^{\text{th}}$  order polynomial equation. Theoretically we can use geometric and/or analytical methods but this can be applied only in some specific cases. Computers can be used to tackle this problem and as they are better with 1<sup>st</sup> order ODEs we break the  $n^{\text{th}}$  order ODE to a system of  $n$  1<sup>st</sup> order ODEs. Also by using matrices we can use powerful tools from linear algebra. The goal of this chapter is to introduce a new approach in the modelling of dynamical systems, the method is called state space analysis and it is far more versatile than the well-known Transfer Functions.

More specifically, the classical control system design techniques (such as root locus and frequency response methods) are generally applicable to:

- a) Single Input Single Output (SISO) systems
- b) Systems that are linear and time invariant (have parameters that do not change with time)

The state space approach is a generalized time domain method for modelling, analysing and designing control systems and is particularly well suited to digital implementation. The state space approach can deal with:

- a) Multi Input Multi Output systems
- b) Non-linear and time variant systems
- c) Alternative controller design approaches

Example:

Assume the simple mass-spring system:

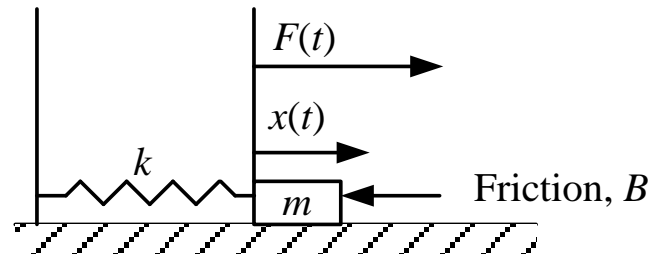

Using Newtonian mechanics we get:

$$\frac{d^2x}{dt^2} = F - B \frac{dx}{dt} - kx = m\ddot{x} = F - B\dot{x} - kx$$

By choosing as  $x_1 = x$ ,  $x_2 = \dot{x}$  we have:

$$\left. \begin{aligned} \dot{x}_1 &= \dot{x} = x_2 \\ \dot{x}_2 &= \ddot{x} = \frac{1}{m}(F - Bx_2 - kx_1) \end{aligned} \right\} \Rightarrow \begin{bmatrix} \dot{x}_1 \\ \dot{x}_2 \end{bmatrix} = \begin{bmatrix} 0 & 1 \\ -\frac{k}{m} & -\frac{B}{m} \end{bmatrix} \begin{bmatrix} x_1 \\ x_2 \end{bmatrix} + \begin{bmatrix} 0 \\ F/m \end{bmatrix}$$

$$\text{Or } \begin{bmatrix} \dot{x}_1 \\ \dot{x}_2 \end{bmatrix} = \begin{bmatrix} 0 & 1 \\ -\frac{k}{m} & -\frac{B}{m} \end{bmatrix} \begin{bmatrix} x_1 \\ x_2 \end{bmatrix} + \begin{bmatrix} 0 \\ 1/m \end{bmatrix} F \Leftrightarrow \dot{x} = Ax + Bu$$

The variables  $x_1$  and  $x_2$  define the state vector  $x$ , which in turn defines the state (a complete summary/description) of the system. Knowing the current state and the future inputs we can predict the future states, i.e. the future behaviour of the system. In the aforementioned case, knowing the values/direction of the force  $F$ , the current displacement  $x$  and speed  $\dot{x}$  of the object we can fully define its future displacement and speed.

In a more general case when we have  $n$  states and  $m$  inputs we have:

$$\begin{aligned}\frac{dx_1}{dt} &= a_{1,1}x_1 + a_{1,2}x_2 + a_{1,3}x_3 + \dots + a_{1,n}x_n + b_{1,1}u_1 + b_{1,2}u_2 + \dots + b_{1,m}u_m \\ \frac{dx_2}{dt} &= a_{2,1}x_1 + a_{2,2}x_2 + a_{2,3}x_3 + \dots + a_{2,n}x_n + b_{2,1}u_1 + b_{2,2}u_2 + \dots + b_{2,m}u_m \\ &\vdots \\ \frac{dx_n}{dt} &= a_{n,1}x_1 + a_{n,2}x_2 + a_{n,3}x_3 + \dots + a_{n,n}x_n + b_{n,1}u_1 + b_{n,2}u_2 + \dots + b_{n,m}u_m\end{aligned}$$

This can be written in a vector form as:

$$\dot{x} = Ax + Bu$$

where:

$$\dot{x} = \begin{bmatrix} \dot{x}_1 \\ \dot{x}_2 \\ \vdots \\ \dot{x}_n \end{bmatrix}, A = \begin{bmatrix} a_{1,1} & a_{1,2} & \dots & a_{1,n} \\ a_{2,1} & \dots & \dots & a_{2,n} \\ \dots & \dots & \dots & \dots \\ a_{n,1} & \dots & \dots & a_{n,n} \end{bmatrix}, x = \begin{bmatrix} x_1 \\ x_2 \\ \vdots \\ x_n \end{bmatrix}, B = \begin{bmatrix} b_{1,1} & \dots & \dots & b_{1,m} \\ \dots & \dots & \dots & \dots \\ b_{n,1} & \dots & \dots & b_{n,m} \end{bmatrix}, u = \begin{bmatrix} u_1 \\ u_2 \\ \vdots \\ u_m \end{bmatrix}$$

Now, in order to “monitor” the system we need sensors to measure various variables like the displacement and velocity of the mass.

Let's assume that we can buy sensors for both variables (the speed and the displacement), then we define the output of the system to be:

$$\begin{bmatrix} y_1 \\ y_2 \end{bmatrix} = \begin{bmatrix} x_1 \\ x_2 \end{bmatrix} \Leftrightarrow y = \begin{bmatrix} 1 & 0 \\ 0 & 1 \end{bmatrix} x \Leftrightarrow y = Cx$$

Let's assume that we can buy only one sensor, that measures the displacement, then the output is:  $y = x_1 \Leftrightarrow y = [1 \ 0]x \Leftrightarrow y = Cx$

Let's assume that we can buy only one sensor, that measures the velocity, then the output is:  $y = x_2 \Leftrightarrow y = [0 \ 1]x \Leftrightarrow y = Cx$

Let's assume that we have only one sensor that measures a linear combination of the displacement and velocity:  $y = a_1x_1 + a_2x_2 \Leftrightarrow y = [a_1 \ a_2]x \Leftrightarrow y = Cx$

Hence, the most general case:

$$\begin{bmatrix} y_1 \\ y_2 \\ \vdots \\ y_p \end{bmatrix} = \begin{bmatrix} c_{1,1}x_1 + c_{1,2}x_2 + \cdots + c_{1,n}x_n \\ c_{2,1}x_1 + c_{2,2}x_2 + \cdots + c_{2,n}x_n \\ \cdots \\ c_{p,1}x_1 + c_{p,2}x_2 + \cdots + c_{p,n}x_n \end{bmatrix} \Leftrightarrow y = \begin{bmatrix} c_{1,1} & c_{1,2} & \cdots & c_{1,n} \\ c_{2,1} & c_{2,2} & \cdots & c_{2,n} \\ \vdots & \ddots & \cdots & \vdots \\ c_{p,1} & c_{p,2} & \cdots & c_{p,n} \end{bmatrix} x \Leftrightarrow y = Cx$$

Finally let's assume that (in a rather artificial case) that the input can directly influence the output, then we have:  $y = Cx + Du$ , For some matrix  $D$ .

So the system is described by  $\begin{matrix} \dot{x} = Ax + Bu \\ y = Cx + Du \end{matrix}$ :

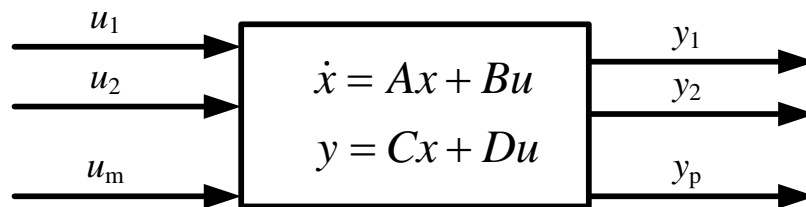

Or in a vector form:

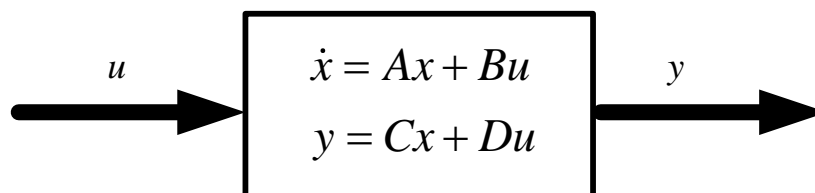

Where: 
$$u = \begin{bmatrix} u_1 \\ u_2 \\ \vdots \\ u_m \end{bmatrix}, \quad y = \begin{bmatrix} y_1 \\ y_2 \\ y_3 \\ \vdots \\ y_p \end{bmatrix}$$

In general: 
$$\dot{x}(t) = A(t)x(t) + B(t)u(t)$$

$$y(t) = C(t)x(t) + D(t)u(t)$$

Where

- $x$  is an  $n \times 1$  state vector, i.e.  $x \in \mathbb{R}^{n \times 1}$
- $u$  is an  $m \times 1$  input vector, i.e.  $u \in \mathbb{R}^{m \times 1}$
- $y$  is an  $p \times 1$  output vector, i.e.  $y \in \mathbb{R}^{p \times 1}$
- $A$  is an  $n \times n$  state matrix, i.e.  $A \in \mathbb{R}^{n \times n}$
- $B$  is an  $n \times m$  input matrix, i.e.  $B \in \mathbb{R}^{n \times m}$
- $C$  is an  $p \times n$  output matrix, i.e.  $C \in \mathbb{R}^{p \times n}$
- $D$  is an  $p \times m$  feed forward matrix (usually zero), i.e.  $D \in \mathbb{R}^{p \times m}$

If the system is Linear Time Invariant (LTI): 
$$\dot{x}(t) = Ax(t) + Bu(t)$$

$$y(t) = Cx(t) + Du(t)$$

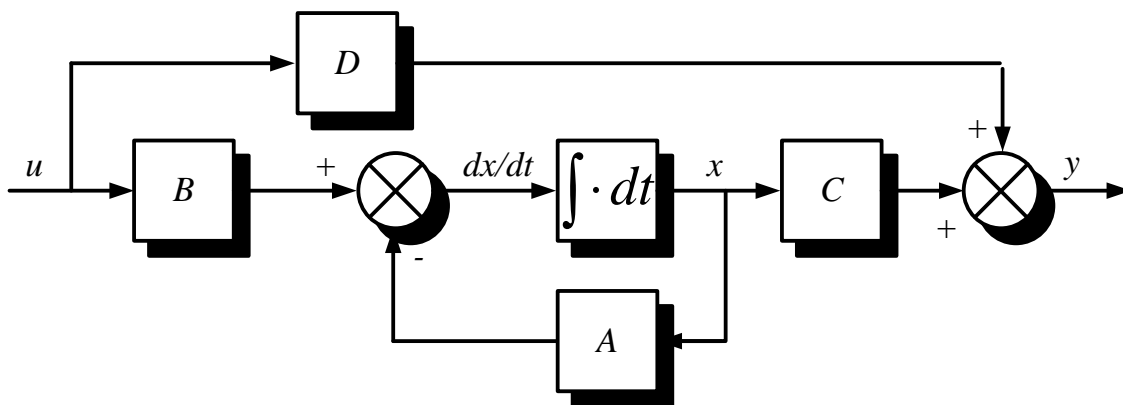

The state of a system is a complete summary of the system at a particular point in time. If the current state of the system and the future input signals are known then it is possible to define the future states and outputs of the system.

The state of a system may be defined as the set of variables (state variables) which at some initial time  $t_0$ , together with the input variables, completely determine the behaviour of the system for time  $t \geq t_0$ .

The state variables are the smallest number of variables that can describe the dynamic nature of a system and it is not a necessary constraint that they are measurable. The manner in which a state variables change with time can be thought of as trajectory in n dimensional space called *state space*. Two dimensional state space is sometimes referred to as the phase plane when one state is the derivative of the other.

The choice of the state space variables is free as long as some rules are followed:

- They must be linearly independent.
- They must specify completely the dynamic behaviour of the system.
- Finally they must not be input of the system.

**Example 2.1:** Find the state space model of the following system:

$$\ddot{x}(t) + 3\dot{x}(t) + 2x(t) = u(t)$$

$$y = 4x(t)$$

$$\left. \begin{aligned} \dot{x}_1 &= \dot{x} = x_2 \\ \dot{x}_2 &= \ddot{x} = u - 3\dot{x} - 2x = u - 3x_2 - 2x_1 \end{aligned} \right\} \Rightarrow \begin{bmatrix} \dot{x}_1 \\ \dot{x}_2 \end{bmatrix} = \begin{bmatrix} 0 & 1 \\ -2 & -3 \end{bmatrix} \begin{bmatrix} x_1 \\ x_2 \end{bmatrix} + \begin{bmatrix} 0 \\ 1 \end{bmatrix} u$$

$$y = 4x = 4x_1 \Leftrightarrow y = \begin{bmatrix} 4 & 0 \end{bmatrix} \begin{bmatrix} x_1 \\ x_2 \end{bmatrix}, A = \begin{bmatrix} 0 & 1 \\ -2 & -3 \end{bmatrix} B = \begin{bmatrix} 0 \\ 1 \end{bmatrix} C = \begin{bmatrix} 4 & 0 \end{bmatrix} \quad \blacksquare$$

**Example 2.2:** Find the state space model of the following system:

$$\ddot{x}(t) = 3\ddot{x}(t) + 2\dot{x}(t) - 2x(t) + u_1(t) - 6u_2(t)$$

$$y_1 = \ddot{x}(t) + u_2(t)$$

$$y_2 = \ddot{x}(t) + 3x(t) + 5u_1(t)$$

$$y_3 = -3\ddot{x}(t) + x(t) + 5u_2(t)$$

Hence:

$$\left. \begin{aligned} x &= x_1 \\ \dot{x} &= x_2 = \dot{x}_1 \\ \ddot{x} &= x_3 = \dot{x}_2 \\ \ddot{x} &= 3\ddot{x} + 2\dot{x} - 2x + u_1 - 6u_2 \Leftrightarrow \\ \dot{x}_3 &= 3x_3 + 2x_2 - 2x_1 + u_1 - 6u_2 \end{aligned} \right\} \Rightarrow \begin{bmatrix} \dot{x}_1 \\ \dot{x}_2 \\ \dot{x}_3 \end{bmatrix} = \begin{bmatrix} 0 & 1 & 0 \\ 0 & 0 & 1 \\ -2 & 2 & 3 \end{bmatrix} \begin{bmatrix} x_1 \\ x_2 \\ x_3 \end{bmatrix} + \begin{bmatrix} 0 & 0 \\ 0 & 0 \\ 1 & -6 \end{bmatrix} \begin{bmatrix} u_1 \\ u_2 \end{bmatrix} \Rightarrow$$

$$\left. \begin{aligned} y_1 &= \ddot{x}(t) + u_2(t) \\ y_2 &= \ddot{x}(t) + 3x(t) + 5u_1(t) \\ y_3 &= -3\ddot{x}(t) + x(t) + 5u_2(t) \end{aligned} \right\} \Rightarrow \left. \begin{aligned} y_1 &= x_3 + u_2 \\ y_2 &= x_3 + 3x_1 + 5u_1(t) \\ y_3 &= -3x_3 + x_1 + 5u_2 \end{aligned} \right\} \Rightarrow$$

$$\begin{bmatrix} y_1 \\ y_2 \\ y_3 \end{bmatrix} = \begin{bmatrix} 0 & 0 & 1 \\ 3 & 0 & 1 \\ 1 & 0 & -3 \end{bmatrix} \begin{bmatrix} x_1 \\ x_2 \\ x_3 \end{bmatrix} + \begin{bmatrix} 0 & 1 \\ 5 & 0 \\ 0 & 5 \end{bmatrix} \begin{bmatrix} u_1 \\ u_2 \end{bmatrix} \quad \blacksquare$$

### Examples of state space models (NOT ASSESSED MATERIAL)

#### Example 2.3

Assume the following simple electromechanical that consists of an electromagnet and

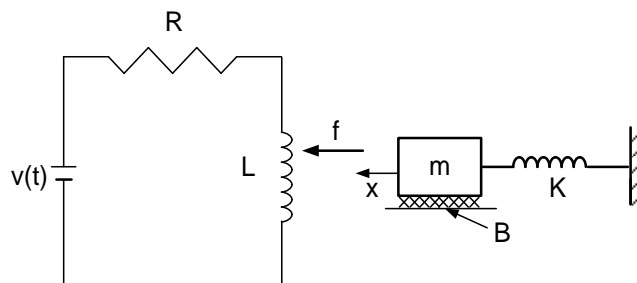

The force of the magnetic field is directly related to the current in the  $RL$  network. The force that is exerted on the object is  $f = k_A \frac{i^2}{x^2}$ , where  $k_A$  is a



positive constant. To simplify the analysis we assume that the displacement  $x$  is very small and in that small area the current has a linear relationship with the force:  $f = k_A i$

$$\text{Using circuit theory: } \frac{di}{dt} = \frac{1}{L}(v - iR)$$

$$\text{Using Newton's 2<sup>nd</sup> law: } f - kx - B\dot{x} = m\ddot{x} \Leftrightarrow k_A i - kx - B\dot{x} = m\ddot{x}$$

Now, we can define  $x_1 = x$ ,  $x_2 = \dot{x}$  and  $x_3 = i$ . Thus:

$$\dot{x}_3 = \frac{1}{L}(v - x_3 R) \Leftrightarrow \dot{x}_3 = -x_3 \frac{R}{L} + \frac{v}{L}$$

$$\dot{x}_1 = \dot{x} = x_2$$

$$m\dot{x}_2 = k_A x_3 - kx_1 - Bx_2 \Leftrightarrow \dot{x}_2 = -\frac{k}{m}x_1 - \frac{B}{m}x_2 + \frac{k_A}{m}x_3$$

Hence the state space model is:

$$\begin{bmatrix} \dot{x}_1 \\ \dot{x}_2 \\ \dot{x}_3 \end{bmatrix} = \begin{bmatrix} 0 & 1 & 0 \\ -k/m & -B/m & -k_A/m \\ 0 & 0 & -R/L \end{bmatrix} \begin{bmatrix} x_1 \\ x_2 \\ x_3 \end{bmatrix} + \begin{bmatrix} 0 \\ 0 \\ 1/L \end{bmatrix} v \Leftrightarrow \dot{\mathbf{x}} = \mathbf{Ax} + \mathbf{Bu}$$

Now let's assume that we have only one sensor that will return the displacement  $x$ :

$$y = \begin{bmatrix} 1 & 0 & 0 \end{bmatrix} \begin{bmatrix} x_1 \\ x_2 \\ x_3 \end{bmatrix}$$

Thus the state space model is:

$$\begin{bmatrix} \dot{x}_1 \\ \dot{x}_2 \\ \dot{x}_3 \end{bmatrix} = \begin{bmatrix} 0 & 1 & 0 \\ -k/m & -B/m & -k_A/m \\ 0 & 0 & -R/L \end{bmatrix} \begin{bmatrix} x_1 \\ x_2 \\ x_3 \end{bmatrix} + \begin{bmatrix} 0 \\ 0 \\ 1/L \end{bmatrix} v$$

$$y = \begin{bmatrix} 1 & 0 & 0 \end{bmatrix} \begin{bmatrix} x_1 \\ x_2 \\ x_3 \end{bmatrix}$$

**Example 2.4**

Another example is shown in the next figure.

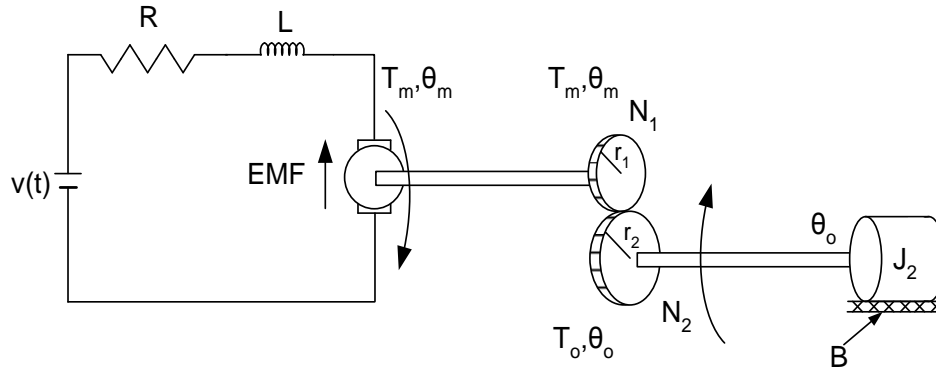

The shaft of the separately excited DC motor is connected to the load  $J_2$  through a gear box.

$$\left. \begin{aligned} J\ddot{\theta}_0 &= T_0 - B\dot{\theta}_0 \\ T_0 &= \frac{n_2}{n_1} T_m \\ T_m &= K_T \phi i_a \end{aligned} \right\} \Rightarrow J\ddot{\theta}_0 = \frac{n_1}{n_2} K_T \phi i_a - B\dot{\theta}_0$$

$$v_a = i_a R_a + L_a \frac{di_a}{dt} + K_T \phi \dot{\theta}_m \Leftrightarrow v_a = i_a R_a + L_a \frac{di_a}{dt} + K_T \phi \frac{n_2}{n_1} \dot{\theta}_0$$

$$\left. \begin{aligned} J\ddot{\theta}_0 &= \frac{n_1}{n_2} K_T \phi i_a - B\dot{\theta}_0 \\ v_a &= i_a R_a + L_a \frac{di_a}{dt} + K_T \phi \frac{n_2}{n_1} \dot{\theta}_0 \end{aligned} \right\} \begin{aligned} K_2 &= K_T \phi \frac{n_1}{n_2} \quad J\ddot{\theta}_0 = K_2 i_a - B\dot{\theta}_0 \\ \Rightarrow \\ K_1 &= K_T \phi \frac{n_2}{n_1} \quad v_a = i_a R_a + L_a \frac{di_a}{dt} + K_1 \dot{\theta}_0 \end{aligned}$$

I define  $\dot{\theta}_0 = x_1$ ,  $i_a = x_2$ :

$$\left. \begin{aligned} J\dot{x}_1 &= K_2 x_2 - Bx_1 \\ v_a &= x_2 R_a + L_a \dot{x}_2 + K_1 x_1 \end{aligned} \right\} \Leftrightarrow \begin{aligned} \dot{x}_1 &= -\frac{B}{J} x_1 + \frac{K_2}{J} x_2 \\ \dot{x}_2 &= -\frac{K_1}{L_a} x_1 - x_2 \frac{R_a}{L_a} + \frac{1}{L_a} v_a \end{aligned} \right\} \Leftrightarrow$$

$$\begin{bmatrix} \dot{x}_1 \\ \dot{x}_2 \end{bmatrix} = \begin{bmatrix} -\frac{B}{J} & \frac{K_2}{J} \\ -\frac{K_1}{L_a} & \frac{R_a}{L_a} \end{bmatrix} \begin{bmatrix} x_1 \\ x_2 \end{bmatrix} + \begin{bmatrix} 0 \\ \frac{1}{L_a} \end{bmatrix} v_a$$

**Example 2.5:**

It can be proved that a model of the Induction Machine is:

$$\left. \begin{aligned}
 \frac{d\psi_{sD}}{dt} &= -R_s i_{sD} + u_{sD} \\
 \frac{d\psi_{sQ}}{dt} &= -R_s i_{sQ} + u_{sQ} \\
 \frac{di_{sD}}{dt} &= \frac{-R_r}{\sigma_1} \psi_{sD} + \frac{-\omega_r L_r}{\sigma_1} \psi_{sQ} + i_{sD} \frac{(L_s R_r + L_r R_s)}{\sigma_1} - i_{sQ} \omega_r - \frac{L_r}{\sigma_1} u_{sD} \\
 \frac{di_{sQ}}{dt} &= \frac{-R_r}{\sigma_1} \psi_{sQ} + \frac{\omega_r L_r}{\sigma_1} \psi_{sD} + i_{sQ} \frac{(L_s R_r + L_r R_s)}{\sigma_1} + i_{sD} \omega_r - \frac{L_r}{\sigma_1} u_{sQ}
 \end{aligned} \right\} \Leftrightarrow$$

$$\begin{bmatrix} \dot{\psi}_{sD} \\ \dot{\psi}_{sQ} \\ \dot{i}_{sD} \\ \dot{i}_{sQ} \end{bmatrix} = \begin{bmatrix} 0 & 0 & -R_s & 0 \\ 0 & 0 & 0 & -R_s \\ \frac{-R_r}{\sigma_1} & \frac{-\omega_r L_r}{\sigma_1} & \frac{(L_s R_r + L_r R_s)}{\sigma_1} & -\omega_r \\ \frac{\omega_r L_r}{\sigma_1} & \frac{-R_r}{\sigma_1} & \omega_r & \frac{(L_s R_r + L_r R_s)}{\sigma_1} \end{bmatrix} \begin{bmatrix} \psi_{sD} \\ \psi_{sQ} \\ i_{sD} \\ i_{sQ} \end{bmatrix} + \begin{bmatrix} 1 & 0 \\ 0 & 1 \\ -\frac{L_r}{\sigma_1} & 0 \\ 0 & -\frac{L_r}{\sigma_1} \end{bmatrix} \begin{bmatrix} u_{sD} \\ u_{sQ} \end{bmatrix}$$

Or:

$$\left. \begin{aligned}
 \frac{di_{sD}}{dt} &= -\frac{R_s}{\sigma L_s} i_{sD} + \frac{\omega_r L_m^2}{L_r \sigma L_s} i_{sQ} + \frac{L_m R_r}{L_r \sigma L_s} i_{rd} + \frac{\omega_r L_m}{\sigma L_s} i_{rq} + \frac{1}{\sigma L_s} u_{sD} \\
 \frac{di_{sQ}}{dt} &= -\frac{\omega_r L_m^2}{L_r \sigma L_s} i_{sD} - \frac{R_s}{\sigma L_s} i_{sQ} - \frac{\omega_r L_m}{\sigma L_s} i_{rd} + \frac{L_m R_r}{L_r \sigma L_s} i_{rq} + \frac{1}{\sigma L_s} u_{sQ} \\
 \frac{di_{rd}}{dt} &= \frac{L_m R_s}{L_r \sigma L_s} i_{sD} - \frac{\omega_r L_m}{\sigma L_r} i_{sQ} - \frac{R_r}{\sigma L_r} i_{rd} - \frac{\omega_r}{\sigma} i_{rq} - \frac{L_m}{L_s \sigma L_r} u_{sD} \\
 \frac{di_{rq}}{dt} &= \frac{\omega_r L_m}{\sigma L_r} i_{sD} + \frac{L_m R_s}{L_r \sigma L_s} i_{sQ} + \frac{\omega_r}{\sigma} i_{rd} - \frac{R_r}{\sigma L_r} i_{rq} - \frac{L_m}{L_s \sigma L_r} u_{sQ}
 \end{aligned} \right\} \Leftrightarrow$$

$$\begin{bmatrix} \frac{di_{sD}}{dt} \\ \frac{di_{sQ}}{dt} \\ \frac{di_{rd}}{dt} \\ \frac{di_{rq}}{dt} \end{bmatrix} = \begin{bmatrix} -\frac{R_s}{\sigma L_s} & \frac{\omega_r L_m^2}{L_r \sigma L_s} & \frac{L_m R_r}{L_r \sigma L_s} & \frac{\omega_r L_m}{\sigma L_s} \\ \frac{\omega_r L_m^2}{L_r \sigma L_s} & -\frac{R_s}{\sigma L_s} & -\frac{\omega_r L_m}{\sigma L_s} & \frac{L_m R_r}{L_r \sigma L_s} \\ \frac{L_m R_s}{L_r \sigma L_s} & -\frac{\omega_r L_m}{\sigma L_r} & -\frac{R_r}{\sigma L_r} & -\frac{\omega_r}{\sigma} \\ \frac{\omega_r L_m}{\sigma L_r} & \frac{L_m R_s}{L_r \sigma L_s} & \frac{\omega_r}{\sigma} & -\frac{R_r}{\sigma L_r} \end{bmatrix} \begin{bmatrix} i_{sD} \\ i_{sQ} \\ i_{rd} \\ i_{rq} \end{bmatrix}$$

$$+ \begin{bmatrix} \frac{1}{\sigma L_s} & 0 \\ 0 & \frac{1}{\sigma L_s} \\ -\frac{L_m}{L_s \sigma L_r} & 0 \\ 0 & -\frac{L_m}{L_s \sigma L_r} \end{bmatrix} \begin{bmatrix} u_{sD} \\ u_{sQ} \end{bmatrix}$$

## State space

The system's states can be written in a vector form as:

$$\mathbf{x}_1 = [x_1, 0, \dots, 0]^T, \mathbf{x}_2 = [0, x_2, \dots, 0]^T, \dots, \mathbf{x}_n = [0, 0, \dots, x_n]^T$$

=> A standard orthogonal basis (since they are linear independent) for an  $n$ -dimensional vector space called state space.

Examples of state spaces are the state plane ( $n=2$ ) and state 3D space ( $n=3$ ),

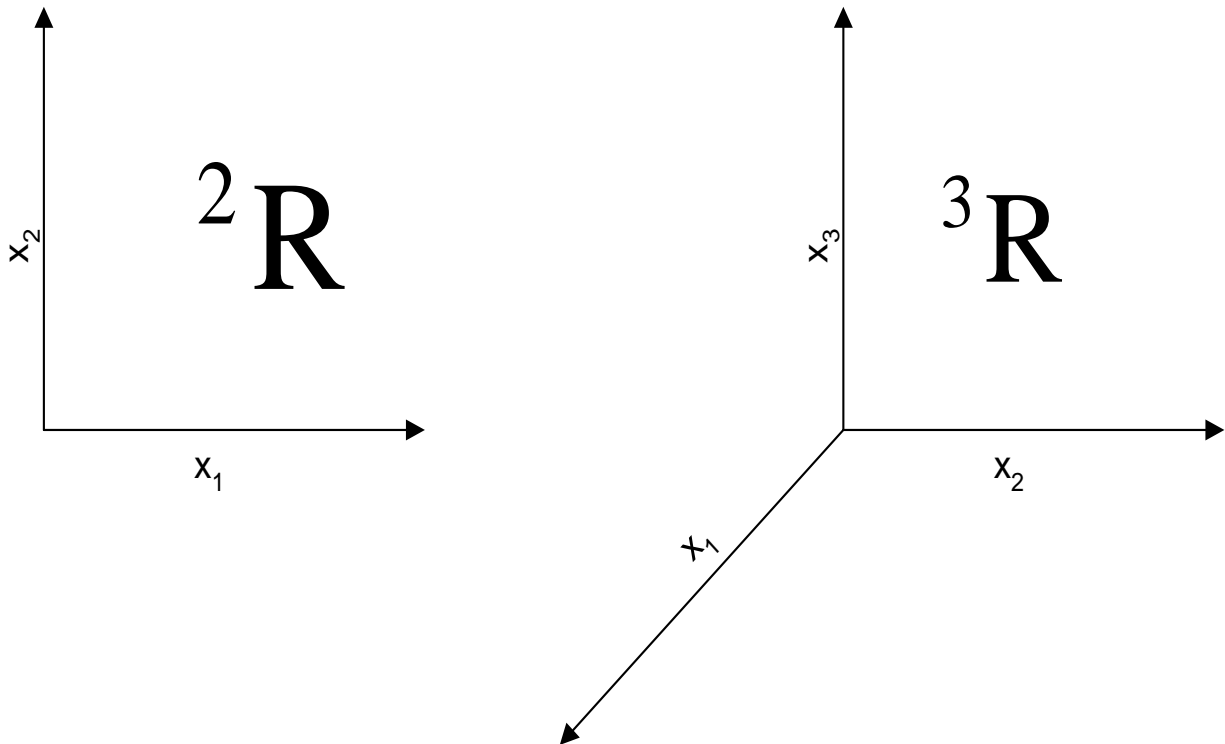

## Relation of state space and TF

If we have an LTI state space (ss) system, how can we find its TF?

$$\dot{x}(t) = Ax(t) + Bu(t) \xrightarrow{LT} sX(s) - x(0) = AX(s) + BU(s) \Rightarrow$$

$$(sI - A)X(s) = BU(s) + x(0) \Rightarrow$$

$$X(s) = (sI - A)^{-1} BU(s) + (sI - A)^{-1} x(0)$$

And from the 2<sup>nd</sup> equation of the ss system:

$$Y(s) = CX(s) + DU(s) \Rightarrow$$

$$Y(s) = C\left((sI - A)^{-1} BU(s) + (sI - A)^{-1} x(0)\right) + DU(s)$$

$$Y(s) = \left(C(sI - A)^{-1} B + D\right)U(s) + C(sI - A)^{-1} x(0)$$

By definition TF:  $C(sI - A)^{-1} B + D$  and  $C(sI - A)^{-1} x(0)$  the response to the IC.

$$\text{Also: } X(s) = (sI - A)^{-1} BU(s) + (sI - A)^{-1} X(0) \xrightarrow{ILT}$$

$$x(t) = L^{-1}\left\{(sI - A)^{-1} BU(s)\right\} + L^{-1}\left\{(sI - A)^{-1}\right\}x(0)$$

$$\text{If } u=0 \Rightarrow X(t) = L^{-1}\left\{(sI - A)^{-1}\right\}X(0)$$

So  $G(s) = C(sI - A)^{-1}B + D$  is the TF. From linear algebra:

$$G_{i,j}(s) = \frac{\begin{vmatrix} sI - A & -B_i \\ C_j & D \end{vmatrix}}{|sI - A|}, \text{ where } B_i \text{ is the } i^{\text{th}} \text{ column of the matrix } B \text{ and } C_j \text{ is the } j^{\text{th}} \text{ row of } C.$$

Hence  $|sI - A|$  is the CE of the TF!!!

$$\text{So: } G(s) = \begin{bmatrix} G_{11}(s) & G_{12}(s) & \dots & G_{1q}(s) \\ G_{21}(s) & G_{22}(s) & \dots & G_{2q}(s) \\ \dots & \dots & \dots & \dots \\ G_{p1}(s) & G_{p2}(s) & \dots & G_{pq}(s) \end{bmatrix}$$

$$\frac{Y_1}{U_1} = G_{11}, \quad \frac{Y_1}{U_2} = G_{12}, \quad \frac{Y_2}{U_1} = G_{21}, \quad \frac{Y_2}{U_2} = G_{22} \dots$$

**Example 2.6:** Find the TF of the following system:

$$\begin{bmatrix} \dot{x}_1 \\ \dot{x}_2 \end{bmatrix} = \begin{bmatrix} 0 & 1 \\ -1 & -0.5 \end{bmatrix} \begin{bmatrix} x_1 \\ x_2 \end{bmatrix} + \begin{bmatrix} 0 \\ 1 \end{bmatrix} u \text{ and } y = \begin{bmatrix} 1 & 0 \end{bmatrix} \begin{bmatrix} x_1 \\ x_2 \end{bmatrix}$$

$$\left. \begin{aligned} |sI - A| &= \begin{vmatrix} s & -1 \\ 1 & s + 0.5 \end{vmatrix} = s(s + 0.5) + 1 \\ \begin{vmatrix} s & -1 & 0 \\ 1 & s + 0.5 & -1 \\ 1 & 0 & 0 \end{vmatrix} &= 1 \end{aligned} \right\} \Rightarrow G(s) = \frac{1}{s(s + 0.5) + 1} \quad \blacksquare$$

**Example 2.7:** Find the TF of the following system:

$$\begin{bmatrix} \dot{x}_1 \\ \dot{x}_2 \end{bmatrix} = \begin{bmatrix} 0 & 1 \\ -1 & -0.5 \end{bmatrix} \begin{bmatrix} x_1 \\ x_2 \end{bmatrix} + \begin{bmatrix} 0 \\ 1 \end{bmatrix} u \quad \text{and} \quad y = \begin{bmatrix} 1 & 0 \\ 0 & 2 \end{bmatrix} \begin{bmatrix} x_1 \\ x_2 \end{bmatrix}$$

$$\left. \begin{array}{l} |sI - A| = \begin{vmatrix} s & -1 \\ 1 & s+0.5 \end{vmatrix} = s(s+0.5)+1 \\ \begin{vmatrix} s & -1 & 0 \\ 1 & s+0.5 & -1 \\ 1 & 0 & 0 \end{vmatrix} = 1 \end{array} \right\} \Rightarrow G_{1,1}(s) = \frac{1}{s(s+0.5)+1}$$

$$\left. \begin{array}{l} |sI - A| = \begin{vmatrix} s & -1 \\ 1 & s+0.5 \end{vmatrix} = s(s+0.5)+1 \\ \begin{vmatrix} s & -1 & 0 \\ 1 & s+0.5 & -1 \\ 0 & 2 & 0 \end{vmatrix} = 1 \end{array} \right\} \Rightarrow G_{2,1}(s) = \frac{2s}{s(s+0.5)+1}$$

Or:

$$G(s) = C(sI - A)^{-1}B + D = \begin{bmatrix} 1 & 0 \\ 0 & 2 \end{bmatrix} \begin{bmatrix} s & -1 \\ 1 & s+0.5 \end{bmatrix}^{-1} \begin{bmatrix} 0 \\ 1 \end{bmatrix} + 0_{2 \times 2}$$

$$\begin{bmatrix} s & -1 \\ 1 & s+0.5 \end{bmatrix}^{-1} = \frac{\begin{bmatrix} s+0.5 & 1 \\ -1 & s \end{bmatrix}}{\begin{vmatrix} s & -1 \\ 1 & s+0.5 \end{vmatrix}} = \frac{\begin{bmatrix} s+0.5 & 1 \\ -1 & s \end{bmatrix}}{s(s+0.5)+1} \Rightarrow$$

$$G(s) = \frac{1}{s(s+0.5)+1} \begin{bmatrix} 1 & 0 \\ 0 & 2 \end{bmatrix} \begin{bmatrix} s+0.5 & 1 \\ -1 & s \end{bmatrix} \begin{bmatrix} 0 \\ 1 \end{bmatrix} \Rightarrow$$

$$G(s) = \frac{1}{s(s+0.5)+1} \begin{bmatrix} 1 & 0 \\ 0 & 2 \end{bmatrix} \begin{bmatrix} 1 \\ s \end{bmatrix} = \frac{1}{s(s+0.5)+1} \begin{bmatrix} 1 \\ 2s \end{bmatrix} \quad \blacksquare$$



**Example 2.8:** Find the TF of the following system:

$$\begin{bmatrix} \dot{x}_1 \\ \dot{x}_2 \end{bmatrix} = \begin{bmatrix} 0 & 1 \\ -1 & -0.5 \end{bmatrix} \begin{bmatrix} x_1 \\ x_2 \end{bmatrix} + \begin{bmatrix} 1 & 1 \\ 0 & 1 \end{bmatrix} u \quad \text{and} \quad y = \begin{bmatrix} 1 & 0 \\ 0 & 2 \end{bmatrix} \begin{bmatrix} x_1 \\ x_2 \end{bmatrix}$$

$$\left. \begin{array}{l} |sI - A| = \begin{vmatrix} s & -1 \\ 1 & s+0.5 \end{vmatrix} = s(s+0.5)+1 \\ \begin{vmatrix} s & -1 & -1 \\ 1 & s+0.5 & 0 \\ 1 & 0 & 0 \end{vmatrix} = s+0.5 \end{array} \right\} \Rightarrow G_{1,1}(s) = \frac{s+0.5}{s(s+0.5)+1}$$

$$\left. \begin{array}{l} |sI - A| = \begin{vmatrix} s & -1 \\ 1 & s+0.5 \end{vmatrix} = s(s+0.5)+1 \\ \begin{vmatrix} s & -1 & -1 \\ 1 & s+0.5 & 0 \\ 0 & 2 & 0 \end{vmatrix} = -2 \end{array} \right\} \Rightarrow G_{2,1}(s) = \frac{-2}{s(s+0.5)+1}$$

$$\left. \begin{array}{l} |sI - A| = \begin{vmatrix} s & -1 \\ 1 & s+0.5 \end{vmatrix} = s(s+0.5)+1 \\ \begin{vmatrix} s & -1 & -1 \\ 1 & s+0.5 & -1 \\ 1 & 0 & 0 \end{vmatrix} = s+3/2 \end{array} \right\} \Rightarrow G_{1,2}(s) = \frac{s+3/2}{s(s+0.5)+1}$$

$$\left. \begin{array}{l} |sI - A| = \begin{vmatrix} s & -1 \\ 1 & s+0.5 \end{vmatrix} = s(s+0.5)+1 \\ \begin{vmatrix} s & -1 & -1 \\ 1 & s+0.5 & -1 \\ 0 & 2 & 0 \end{vmatrix} = 2s-2 \end{array} \right\} \Rightarrow G_{2,2}(s) = \frac{2s-2}{s(s+0.5)+1}$$

Or:

$$G(s) = C(sI - A)^{-1}B + D = \begin{bmatrix} 1 & 0 \\ 0 & 2 \end{bmatrix} \begin{bmatrix} s & -1 \\ 1 & s+0.5 \end{bmatrix}^{-1} \begin{bmatrix} 1 & 1 \\ 0 & 1 \end{bmatrix} + 0_{2 \times 2}$$

$$\begin{bmatrix} s & -1 \\ 1 & s+0.5 \end{bmatrix}^{-1} = \frac{\begin{bmatrix} s+0.5 & 1 \\ -1 & s \end{bmatrix}}{\begin{vmatrix} s & -1 \\ 1 & s+0.5 \end{vmatrix}} = \frac{\begin{bmatrix} s+0.5 & 1 \\ -1 & s \end{bmatrix}}{s(s+0.5)+1} \Rightarrow$$

$$G(s) = \frac{1}{s(s+0.5)+1} \begin{bmatrix} 1 & 0 \\ 0 & 2 \end{bmatrix} \begin{bmatrix} s+0.5 & 1 \\ -1 & s \end{bmatrix} \begin{bmatrix} 1 & 1 \\ 0 & 1 \end{bmatrix} \Rightarrow$$

$$G(s) = \frac{1}{s(s+0.5)+1} \begin{bmatrix} s+0.5 & 1 \\ -2 & 2s \end{bmatrix} \begin{bmatrix} 1 & 1 \\ 0 & 1 \end{bmatrix}$$

$$G(s) = \frac{1}{s(s+0.5)+1} \begin{bmatrix} s+0.5 & s+0.5+1 \\ -2 & -2+2s \end{bmatrix} \quad \blacksquare$$

### Observability

Assume that we have the following system:

$$\left. \begin{aligned} \dot{x} &= \begin{bmatrix} -2 & 0 \\ 0 & -1 \end{bmatrix} x + \begin{bmatrix} 2 \\ 1 \end{bmatrix} u \\ y &= \begin{bmatrix} 3 & 0 \end{bmatrix} x \end{aligned} \right\}$$

Notice that the model is uncoupled and since  $C$  is  $1 \times 2$  it is impossible to see how  $x_2$  behaves (no problem if  $A$  was not diagonal or  $C$  was  $I_2$ ). This implies that we cannot monitor  $x_2$ , for example it can diverge to infinity with catastrophic results for our system.

Assume that we have another system: 
$$\left. \begin{aligned} \dot{x} &= -2x + 2u \\ y &= 3x \end{aligned} \right\}$$

Clearly these two models are different. In that case it can be proved that the 2 systems have the same transfer function as there is a pole-zero cancellation:

$$\left. \begin{array}{l} \dot{x} = -2x + 2u \\ y = 3x \end{array} \right\} \Rightarrow G(s) = \frac{\begin{vmatrix} sI - A & -B \\ C & D \end{vmatrix}}{|sI - A|} = \frac{6}{s+2}$$

$$\left. \begin{array}{l} \dot{x} = \begin{bmatrix} -2 & 0 \\ 0 & -1 \end{bmatrix} x + \begin{bmatrix} 2 \\ 1 \end{bmatrix} u \\ y = \begin{bmatrix} 3 & 0 \end{bmatrix} x \end{array} \right\} \Rightarrow G(s) = \frac{\begin{vmatrix} sI - A & -B \\ C & D \end{vmatrix}}{|sI - A|} = \frac{6(s+1)}{(s+2)(s+1)} = \frac{6}{(s+2)}$$

which is exactly the same as the TF of the first system, what is wrong? There is a pole zero cancellation at the second model

### Controllability

Assume that we have the following system:

$$\left. \begin{array}{l} \dot{x} = \begin{bmatrix} -2 & 0 \\ 0 & -1 \end{bmatrix} x + \begin{bmatrix} 2 \\ 0 \end{bmatrix} u \\ y = \begin{bmatrix} 3 & 2 \end{bmatrix} x \end{array} \right\}$$

In this case we can see how both states behave but we cannot change  $u$  in any way so that we can influence  $x_2$  due to the form of  $B$ . If  $A$  was not diagonal we would be able to control  $x_2$  through  $x_1$ .

Similarly we have a pole-zero cancellation in:

$$\left. \begin{array}{l} \dot{x} = \begin{bmatrix} -2 & 0 \\ 0 & -1 \end{bmatrix} x + \begin{bmatrix} 2 \\ 0 \end{bmatrix} u \\ y = \begin{bmatrix} 3 & 2 \end{bmatrix} x \end{array} \right\} \Rightarrow G(s) = \frac{\begin{vmatrix} sI - A & -B \\ C & D \end{vmatrix}}{|sI - A|} = \frac{6(s+1)}{(s+2)(s+1)} = \frac{6}{(s+2)}$$

Hence in the first case by properly defining  $u$  we can control both states but we cannot see the second state, while in the second case we can see both states but we cannot control the second state. The first system is called **unobservable** and the second **uncontrollable**. The loss of the controllability and/or observability is due to a pole/zero cancellation. These systems are unacceptable and the solution to that problem is to re-model the system.

The systems that are both controllable and observable are called **minimal realisation**.

We need to develop tests to determine the controllability and observability properties of the system. Difficult task if the system is nonlinear. In our case we simply have to find the rank (the number of Linear Independent (LI) rows or columns) of two matrices.

For observability:

$M_o = [C \quad CA \quad CA^2 \quad \dots \quad CA^{n-1}]^T$ . If the rank of this matrix is less than  $n$  then the system is unobservable.

For controllability:

$M_c = [B \quad AB \quad A^2B \quad \dots \quad A^{n-1}B]$ . If the rank of this matrix is less than  $n$  then the system is uncontrollable.



**Example 2.9:** Determine the Observability of the following system:

$$\left. \begin{aligned} \dot{x} &= \begin{bmatrix} -2 & 0 \\ 0 & -1 \end{bmatrix} x + \begin{bmatrix} 2 \\ 1 \end{bmatrix} u \\ y &= [3 \ 0]x \end{aligned} \right\} \Rightarrow CA = [3 \ 0] \begin{bmatrix} -2 & 0 \\ 0 & -1 \end{bmatrix} = [-6 \ 0]$$

$$M_o = \begin{bmatrix} 3 & 0 \\ -6 & 0 \end{bmatrix}$$

And obviously there is only one LI column/row ■

**Example 2.10:** Determine the Observability of the following system:

$$\left. \begin{aligned} \dot{x} &= \begin{bmatrix} -2 & 0 \\ 0 & -1 \end{bmatrix} x + \begin{bmatrix} 2 \\ 1 \end{bmatrix} u \\ y &= [3 \ 2]x \end{aligned} \right\} \Rightarrow CA = [3 \ 2] \begin{bmatrix} -2 & 0 \\ 0 & -1 \end{bmatrix} = [-6 \ -2]$$

$$M_o = \begin{bmatrix} 3 & 2 \\ -6 & -2 \end{bmatrix}$$

And obviously there are 2 LI column/rows ■

**Example 2.11:** Determine the Observability of the following system:

$$\left. \begin{aligned} \dot{x} &= \begin{bmatrix} -2 & 0 \\ 0 & -1 \end{bmatrix} x + \begin{bmatrix} 2 \\ 0 \end{bmatrix} u \\ y &= [3 \ 2]x \end{aligned} \right\} \Rightarrow AB = \begin{bmatrix} -2 & 0 \\ 0 & -1 \end{bmatrix} \begin{bmatrix} 2 \\ 0 \end{bmatrix} = \begin{bmatrix} -4 \\ 0 \end{bmatrix}$$

$$M_c = \begin{bmatrix} 2 & -4 \\ 0 & 0 \end{bmatrix}$$

And obviously there is only one LI column/row ■

**Example 2.12:** Determine the Observability of the following system:

$$\left. \begin{aligned} \dot{x} &= \begin{bmatrix} -2 & 0 \\ 0 & -1 \end{bmatrix} x + \begin{bmatrix} 2 \\ 1 \end{bmatrix} u \\ y &= [3 \ 2]x \end{aligned} \right\} \Rightarrow AB = \begin{bmatrix} -2 & 0 \\ 0 & -1 \end{bmatrix} \begin{bmatrix} 2 \\ 1 \end{bmatrix} = \begin{bmatrix} -4 \\ -1 \end{bmatrix}$$

$$M_c = \begin{bmatrix} 2 & -4 \\ 1 & -1 \end{bmatrix}$$

And obviously there are 2 LI column/rows. ■

## Tutorial Exercise II

1. Derive a state space representation of the mass spring system assuming that the system has 2 outputs: the displacement and the velocity.
2. Repeat Question 1 assuming that the displacement is the only system output.
3. Find the state space model of the following system:

$$\ddot{x} + 6\dot{x} + 5x = u(t)$$

$$y = 4\dot{x} + x$$

4. A state space model is given by

$$A = \begin{bmatrix} 1 & 2 & 3 & 4 & 5 \\ 6 & 7 & 8 & 9 & 10 \\ 11 & 12 & 13 & 14 & 15 \\ 16 & 17 & 18 & 19 & 20 \\ 21 & 22 & 23 & 24 & 25 \end{bmatrix}, B = \begin{bmatrix} -0.1 & -0.2 & -0.3 \\ -0.4 & -0.5 & -0.6 \\ -0.7 & -0.9 & -1 \\ -1.1 & -1.2 & -1.3 \\ -1.4 & -1.5 & -1.6 \end{bmatrix},$$

$$C = \begin{bmatrix} 1 & 1 & 2 & 2 & 3 \\ 0 & 0 & 0 & -1 & 152 \end{bmatrix}, D = 0$$

- (a) What is the order of the system?
- (b) How many inputs/ outputs do we have in this system?
- (c) What are the dimensions of the matrix  $D$ ?
5. Find the state space model of:

$$(a) \left. \begin{aligned} x^{(4)} &= 3x^{(3)} + 4x'' - 3x' + x + u_1 - 3u_2 + 5u_3 \\ y_1 &= x^{(3)} + u_1 \\ y_2 &= x^{(4)} + 1.2x' + u_3 - u_1 \\ y_3 &= x \end{aligned} \right\}$$

$$(b) \left. \begin{aligned} \dot{x}_1 &= 3x_1 + 3x_2 + u_1 + u_2 + u_3 + u_4 \\ \dot{x}_2 &= 3x_2 + u_1 - 2u_3 \\ y_1 &= x_1 \\ y_2 &= x_1 + 3x_2 + u_1 + u_2 \\ y_3 &= x_1 - 2x_2 + u_3 + u_4 \end{aligned} \right\}$$

In each case find:

- The order of the system?
  - How many inputs/ outputs do we have in this system?
6. Find the transfer function of a system with:

$$A = \begin{bmatrix} 1 & 2 \\ 3 & 4 \end{bmatrix}, B = \begin{bmatrix} 1 \\ 0 \end{bmatrix}, C = [1 \quad 1], D = 0.$$

7. Find the transfer function of a system with:

$$A = \begin{bmatrix} 1 & 2 \\ 3 & 4 \end{bmatrix}, B = \begin{bmatrix} 1 & 1 \\ 0 & 1 \end{bmatrix}, C = [1 \quad 1], D = [0 \quad 0].$$

8. Find the transfer function of a system with:

$$A = \begin{bmatrix} 1 & 2 \\ 3 & 4 \end{bmatrix}, B = \begin{bmatrix} 1 & 1 \\ 0 & 1 \end{bmatrix}, C = \begin{bmatrix} 1 & 1 \\ 0 & 1 \end{bmatrix}, D = \begin{bmatrix} 0 & 0 \\ 0 & 0 \end{bmatrix}.$$

9. What is the characteristic equation in Q.6-8? What is the system order? Is that system stable? Why? Are these systems observable/controllable?