

Chapter #2

EEE8115-EEE8086

Robust and Adaptive Control Systems

State Space Analysis	2
1. General material.....	2
2. Solution of a state space model.....	3
3. State space transformations.....	3
4. Normal or Canonical Form	7
4.1 Case 1: Real and distinct eigenvalues.....	7
4.2 Case 2: Complex and distinct eigenvalues.....	10
4.3 Case 3: Repeated Real Eigenvalues	14
4.3 Case 4: Repeated Complex Eigenvalues.....	17
5. Exercises	18
6. Matlab Based Exercises for EEE8086	18

State Space Analysis

1. General material

The state space model of an n^{th} order system, with q inputs and p outputs is given by:

$$\begin{aligned}\dot{x}(t) &= A(t)x(t) + B(t)u(t) \\ y(t) &= C(t)x(t) + D(t)u(t)\end{aligned}\tag{1}$$

with $x \in \mathbb{R}^{n \times 1}$, $u \in \mathbb{R}^{q \times 1}$, $y \in \mathbb{R}^{p \times 1}$, $A \in \mathbb{R}^{n \times n}$, $B \in \mathbb{R}^{n \times q}$, $C \in \mathbb{R}^{p \times n}$, $D \in \mathbb{R}^{p \times q}$

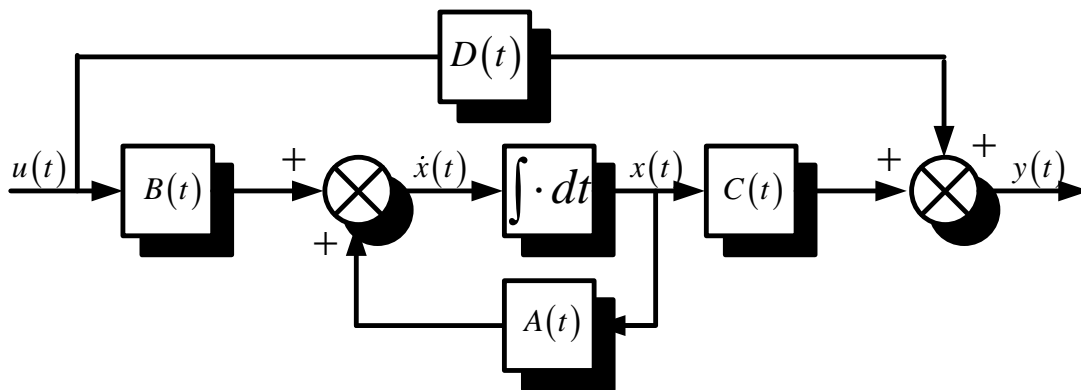

If the system is Linear Time Invariant (LTI):

$$\begin{aligned}\dot{x}(t) &= Ax(t) + Bu(t) \\ y(t) &= Cx(t) + Du(t)\end{aligned}\tag{2}$$

The system's states can be written in a vector form as:

$$x_1 = [x_1, 0, \dots, 0]^T, x_2 = [0, x_2, \dots, 0]^T, \dots, x_n = [0, 0, \dots, x_n]^T$$

=> A standard orthogonal basis (since they are linear independent) for an n -dimensional vector space called state space.

Examples of state spaces are the state plane ($n=2$) and state 3D space ($n=3$),

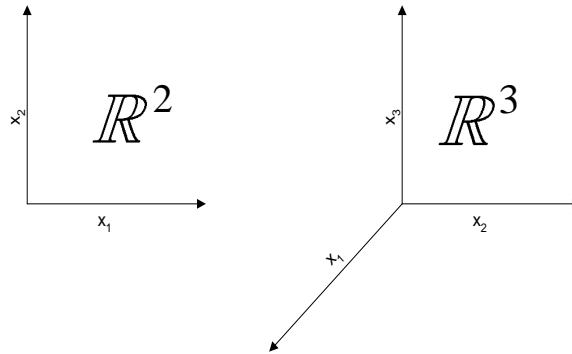

2. Solution of a state space model

Using the analysis from Chapter 1 it is easy to see that the solution of a state space model is given by:

$$x(t) = e^{At}x(0) + \int_0^t e^{A(t-\tau)}Bu d\tau \quad (3)$$

3. State space transformations

State space representations are not unique. We can have (linearly) equivalent forms with the same input/output properties like same eigenvalues. So for a state space model such as:

$$\dot{x}(t) = Ax(t) + Bu(t), \quad y(t) = Cx(t) + Du(t)$$

Assume that $x = Tz$, $T \in \mathbb{R}^{n \times n}$, $z \in \mathbb{R}^{n \times 1}$. T is an invertible matrix (not singular) and z is the new state vector:

So $z = T^{-1}x \Rightarrow \dot{z} = T^{-1}\dot{x} \Rightarrow \dot{z} = T^{-1}Ax(t) + T^{-1}Bu(t)$

$\dot{z} = T^{-1}ATz + T^{-1}Bu(t) \Rightarrow \dot{z} = \hat{A}z + \hat{B}u(t)$, where $\hat{A} = T^{-1}AT$ is the state matrix and $\hat{B} = T^{-1}B$ is the new input matrix.

And $y(t) = CTz + Du(t) \Rightarrow y(t) = \hat{C}z + \hat{D}u(t)$, where $\hat{C} = CT$ is the new output matrix and $\hat{D} = D$ is the new input/output coupling matrix.

Do these two systems have the same TF?

$$G_1(s) = C(sI - A)^{-1}B + D \text{ and } G_2(s) = \hat{C}(sI - \hat{A})^{-1}\hat{B} + \hat{D}$$

$$G_1(s) = C(TT^{-1})(sI - A)^{-1}(TT^{-1})B + \hat{D} \Leftrightarrow$$

$$G_1(s) = CT(T(sI - A)T^{-1})^{-1}T^{-1}B + \hat{D} \Leftrightarrow$$

$$G_1(s) = \hat{C}((sI - TAT^{-1}))^{-1}\hat{B} + \hat{D} \Leftrightarrow$$

$$G_1(s) = \hat{C}(sI - \hat{A})^{-1}\hat{B} + \hat{D} = G_2(s)$$

Example 1.1: A state matrix is given by $A = \begin{bmatrix} 1 & 2 \\ 3 & 4 \end{bmatrix}$ with eigenvalues¹ 5.3723

and -0.3723. Find its transformed matrix $\hat{A} = T^{-1}AT$, with $T = \begin{bmatrix} 5 & 6 \\ 7 & 8 \end{bmatrix}$ and

the new eigenvalues²:

$$\hat{A} = T^{-1}AT = \begin{bmatrix} 53 & 62 \\ -41 & -48 \end{bmatrix} \Rightarrow \hat{\lambda}_1 = -0.3723, \hat{\lambda}_2 = 5.3723 \quad \blacksquare$$

¹ A=[1 2;3 4]; eig(A)

² T=[5 6;7 8];Ah=inv(T)*A*T;eig(Ah)

Example 1.2: The state space model of a system is given by $A = \begin{bmatrix} 1 & 2 \\ 3 & 4 \end{bmatrix}$,

$B = \begin{bmatrix} 1 & 0 \\ 3 & 4 \end{bmatrix}$, $C = \begin{bmatrix} 1 & 0 \\ 0 & 1 \\ 1 & 1 \end{bmatrix}$, find its TF with respect to the first input/output, and

find the new TF (again with respect to the first input/output) if it is transformed by $T = \begin{bmatrix} 5 & 6 \\ 7 & 8 \end{bmatrix}$: $G_1(s) = G_2(s) = \frac{s+2}{s^2-5s-2}$ ■³

Example 1.3: For the system of Example 1.2, find the controllability and observability matrices and prove that both systems are (as expected) controllable and observable:

$$O_1 = \begin{bmatrix} 1 & 0 \\ 0 & 1 \\ 1 & 1 \\ 1 & 2 \\ 3 & 4 \\ 4 & 6 \end{bmatrix} \Rightarrow \text{rank}(O_1) = 2; O_2 = \begin{bmatrix} 5 & 6 \\ 7 & 8 \\ 12 & 14 \\ 19 & 22 \\ 43 & 50 \\ 62 & 72 \end{bmatrix} \Rightarrow \text{rank}(O_2) = 2;$$

$$C_1 = \begin{bmatrix} 1 & 0 & 7 & 8 \\ 3 & 4 & 15 & 16 \end{bmatrix} \Rightarrow \text{rank}(C_1) = 2; C_2 = \begin{bmatrix} 5 & 12 & 17 & 16 \\ -4 & -10 & -13 & -12 \end{bmatrix} \Rightarrow \text{rank}(C_2) = 2;$$

■⁴

³ $T = [5 \ 6; 7 \ 8]; A = [1 \ 2; 3 \ 4]; B = [1 \ 0; 3 \ 4]; C = [1 \ 0; 0 \ 1; 1 \ 1]; A_h = \text{inv}(T) * A * T; B_h = \text{inv}(T) * B; C_h = C * T;$
 $\text{sys1} = \text{ss}(A, B, C, \text{zeros}(3, 2)); \text{sys2} = \text{ss}(A_h, B_h, C_h, \text{zeros}(3, 2)); [\text{num1}, \text{den1}] = \text{ss2tf}(A, B, C, \text{zeros}(3, 2), 1)$
 $[\text{num2}, \text{den2}] = \text{ss2tf}(A_h, B_h, C_h, \text{zeros}(3, 2), 1)$

⁴ $\text{obsv}(A, C); \text{obsv}(A_h, C_h); \text{ctrb}(A, B); \text{ctrb}(A_h, B_h)$

Now, in EEE8013 we have seen that the state transition matrix (STM) for a linear time invariant (LTI) system is given by e^{At} . Obviously the new system will also be LTI and hence its STM will be $e^{\hat{A}t}$. So what is the connection between the two STMs? We have seen something similar in EEE8013 but we repeat it here for completeness.

By definition the STM of the initial system is given by

$$\begin{aligned} e^{At} &= I + At + \frac{1}{2!}(At)^2 + \frac{1}{3!}(At)^3 + \dots \\ &= I + (T\hat{A}T^{-1})t + \frac{1}{2!}((T\hat{A}T^{-1})t)^2 + \frac{1}{3!}((T\hat{A}T^{-1})t)^3 + \dots \end{aligned}$$

$$\text{But } (T\hat{A}T^{-1})^2 = (T\hat{A}T^{-1})(T\hat{A}T^{-1}) = T\hat{A}^2T^{-1}$$

So

$$\begin{aligned} e^{At} &= TIT^{-1} + (T\hat{A}T^{-1})t + \frac{1}{2!}(T\hat{A}^2T^{-1})t^2 + \frac{1}{3!}(T\hat{A}^3T^{-1})t^3 + \dots = \\ &= T\left(I + (\hat{A})t + \frac{1}{2!}(\hat{A}^2)t^2 + \frac{1}{3!}(\hat{A}^3)t^3 + \dots\right)T^{-1} = \\ &= Te^{\hat{A}t}T^{-1} \end{aligned}$$

4. Normal or Canonical Form

We have seen that a similarity transformation transforms a state space model into another “equivalent” form using the formula: $x = Tz$, where x, z are $n \times 1$ vectors and T is an **invertible** $n \times n$ matrix. This means that the new system will have the same eigenvalues but different eigenvectors. The only requirement is that T is invertible. But what will happen if T has a specific form? I.e. we place some specific conditions on T that must be satisfied. In this section we will investigate this transformation when T is the eigenmatrix. For simplicity we will only study homogenous systems:

$$x = Tz \Leftrightarrow \dot{x} = T\dot{z} \Leftrightarrow Ax = T\dot{z} \Leftrightarrow ATz = T\dot{z} \Leftrightarrow \dot{z} = \underbrace{T^{-1}AT}_{\hat{A}}z$$

Hence the new “equivalent” model of $\dot{x} = Ax$ is $\dot{z} = \hat{A}z$ with $\hat{A} = T^{-1}AT$, where T is the eigenmatrix of A . We have also seen that $e^{At} = Te^{\hat{A}t}T^{-1}$. So the question here is what will be the form of the new STM, the form of the eigenvectors and how the new STM can be used to find the STM of the original model. As before we have 3 cases for 2 dimensional systems:

4.1 Case 1: Real and distinct eigenvalues

In that case we have the 2 eigenvalues λ_1, λ_2 and $T = \begin{bmatrix} e_1 & e_2 \end{bmatrix}$ (e_1, e_2 are the 2 LI eigenvectors) then we have:

$$AT = A \begin{bmatrix} e_1 & e_2 \end{bmatrix} = \begin{bmatrix} Ae_1 & Ae_2 \end{bmatrix} = \begin{bmatrix} \lambda_1 e_1 & \lambda_2 e_2 \end{bmatrix} = \begin{bmatrix} e_1 & e_2 \end{bmatrix} \begin{bmatrix} \lambda_1 & 0 \\ 0 & \lambda_2 \end{bmatrix}$$

Hence, $AT = T\hat{A} = T\Lambda$, $\Lambda = \hat{A} = \begin{bmatrix} \lambda_1 & 0 \\ 0 & \lambda_2 \end{bmatrix}$

Example 1.4: Find the normal form of $A = \begin{bmatrix} 1 & 2 \\ 3 & 4 \end{bmatrix}$: $\hat{A} = \begin{bmatrix} -0.3723 & 0 \\ 0 & 5.3723 \end{bmatrix}$ ■⁵

The eigenvectors of the new state matrix \hat{A} are found to be:

$$\lambda = \lambda_1 \Rightarrow \left(\begin{bmatrix} \lambda_1 & 0 \\ 0 & \lambda_2 \end{bmatrix} - \lambda_1 I \right) e = 0 \Leftrightarrow \begin{bmatrix} 0 & 0 \\ 0 & \lambda_2 - \lambda_1 \end{bmatrix} \begin{bmatrix} x \\ y \end{bmatrix} = 0 \Rightarrow \begin{cases} x = \text{anything} = 1 \\ y = 0 \end{cases}$$

$$\lambda = \lambda_2 \Rightarrow \left(\begin{bmatrix} \lambda_1 & 0 \\ 0 & \lambda_2 \end{bmatrix} - \lambda_2 I \right) e = 0 \Leftrightarrow \begin{bmatrix} \lambda_1 - \lambda_2 & 0 \\ 0 & 0 \end{bmatrix} \begin{bmatrix} x \\ y \end{bmatrix} = 0 \Rightarrow \begin{cases} x = 0 \\ y = \text{anything} = 1 \end{cases}$$

Thus we see that the new eigenvectors are $[1 \ 0]^T$, $[0 \ 1]^T$.

Now the STM of the new model is:

$$\begin{aligned} e^{\hat{A}t} &= I + \hat{A}t + \frac{\hat{A}^2 t^2}{2!} + \dots = I + \begin{bmatrix} \lambda_1 & 0 \\ 0 & \lambda_2 \end{bmatrix} t + \begin{bmatrix} \lambda_1 & 0 \\ 0 & \lambda_2 \end{bmatrix} \begin{bmatrix} \lambda_1 & 0 \\ 0 & \lambda_2 \end{bmatrix} \frac{t^2}{2!} + \dots \\ &= I + \begin{bmatrix} \lambda_1 & 0 \\ 0 & \lambda_2 \end{bmatrix} t + \begin{bmatrix} \lambda_1^2 & 0 \\ 0 & \lambda_2^2 \end{bmatrix} \frac{t^2}{2!} + \dots = \begin{bmatrix} 1 + \lambda_1 t + \lambda_1^2 \frac{t^2}{2!} \dots & 0 \\ 0 & 1 + \lambda_2 t + \lambda_2^2 \frac{t^2}{2!} \dots \end{bmatrix} \end{aligned}$$

But by the definition of the Taylor Series expansion of $e^{\lambda t}$ is: $e^{\lambda t} = 1 + \lambda t + \lambda^2 \frac{t^2}{2!} \dots$

⁵ $A = [1 \ 2; 3 \ 4]$; $[x, v] = \text{eig}(A)$; $Ah = \text{inv}(x) * A * x$

Hence we have that $e^{\hat{A}t} = \begin{bmatrix} e^{\lambda_1 t} & 0 \\ 0 & e^{\lambda_2 t} \end{bmatrix}$. Thus the STM of the original system is:

$$e^{At} = T \begin{bmatrix} e^{\lambda_1 t} & 0 \\ 0 & e^{\lambda_2 t} \end{bmatrix} T^{-1} \text{ and this is another way to find the STM of a model}$$

whose state matrix has real and distinct eigenvalues.

Example 1.5: Find the STM matrix of $A = \begin{bmatrix} 1 & 2 \\ 3 & 4 \end{bmatrix}$ and evaluate it at $t=1$.

$$e^{At} = T \begin{bmatrix} e^{-0.3723t} & 0 \\ 0 & e^{5.3723t} \end{bmatrix} T^{-1} \stackrel{t=1}{=} \begin{bmatrix} 51.9690 & 74.7366 \\ 112.1048 & 164.0738 \end{bmatrix} \quad \blacksquare^6$$

Obviously if we have an n^{th} order system with only real and distinct eigenvalues then the new state matrix is:

$$\hat{A} = T^{-1}AT = \begin{bmatrix} \lambda_1 & 0 & 0 & 0 \\ 0 & \lambda_2 & 0 & 0 \\ 0 & 0 & \ddots & 0 \\ 0 & 0 & 0 & \lambda_n \end{bmatrix}, \text{ with } T = \begin{bmatrix} e_1 & e_2 & \cdots & e_n \end{bmatrix}, \text{ and the}$$

eigenvectors of \hat{A} are: $\begin{bmatrix} 1 & 0 & \cdots & 0 \end{bmatrix}^T, \begin{bmatrix} 0 & 1 & \cdots & 0 \end{bmatrix}^T, \dots, \begin{bmatrix} 0 & 0 & \cdots & 1 \end{bmatrix}^T,$

$$\text{while the new STM is: } e^{\hat{A}t} = \begin{bmatrix} e^{\lambda_1 t} & 0 & 0 & 0 \\ 0 & e^{\lambda_2 t} & 0 & 0 \\ 0 & 0 & \ddots & 0 \\ 0 & 0 & 0 & e^{\lambda_n t} \end{bmatrix}$$

⁶ $A = [1 \ 2; 3 \ 4]; [x, v] = \text{eig}(A); x1 = x(:, 1) / \min(\text{abs}(x(:, 1))); x2 = x(:, 2) / \min(\text{abs}(x(:, 2))); T = [x1 \ x2]; e_Lam = [\exp(v(1, 1)) \ 0; 0 \ \exp(v(2, 2))]; e_A = T * e_Lam * \text{inv}(T), \text{expm}(A)$

4.2 Case 2: Complex and distinct eigenvalues

In this case the eigenvalues are $\lambda_1 = \bar{\lambda}_2 = a + bi$ and the eigenvectors are of

the form: $e_1 = \bar{e}_2 = v + wi$ and hence we have:

$$\begin{aligned} Ae_1 = \lambda_1 e_1 &\Leftrightarrow A(v + wi) = (v + wi)(a + bi) \Leftrightarrow \\ Av + Awi &= va - wb + (vb + wa)i \Rightarrow \\ \left\{ \begin{array}{l} Av = va - wb \\ Aw = vb + wa \end{array} \right\} &\Rightarrow \\ A \begin{bmatrix} v & w \end{bmatrix} &= \begin{bmatrix} v & w \end{bmatrix} \begin{bmatrix} a & b \\ -b & a \end{bmatrix} \end{aligned}$$

So if we choose $T = \begin{bmatrix} \text{Re}(e) & \text{Im}(e) \end{bmatrix} = \begin{bmatrix} v & w \end{bmatrix}$ we have that:

$$\hat{A} = T^{-1}AT = \begin{bmatrix} \text{Re}(\lambda) & \text{Im}(\lambda) \\ -\text{Im}(\lambda) & \text{Re}(\lambda) \end{bmatrix} = \begin{bmatrix} a & b \\ -b & a \end{bmatrix}.$$

Example 1.6: Find the normal form of $A = \begin{bmatrix} 0 & 1 \\ -5 & -4 \end{bmatrix}$:

$$\hat{A} = T^{-1}AT = \begin{bmatrix} -2 & 1 \\ -1 & -2 \end{bmatrix} \quad \blacksquare^7$$

⁷ $A = [0 \ 1; -5 \ -4]$; $[x,v] = \text{eigs}(A)$; $T = [\text{real}(x(:,1)) \ \text{imag}(x(:,1))]$; $\text{inv}(T) * A * T$

Now, the new eigenvectors of the 2x2 system are given by:

$$\left(\begin{bmatrix} \operatorname{Re}(\lambda) & \operatorname{Im}(\lambda) \\ -\operatorname{Im}(\lambda) & \operatorname{Re}(\lambda) \end{bmatrix} - \lambda I \right) e$$

This can be written as: $\begin{bmatrix} \operatorname{Re}(\lambda) - \lambda & \operatorname{Im}(\lambda) \\ -\operatorname{Im}(\lambda) & \operatorname{Re}(\lambda) - \lambda \end{bmatrix} e = 0$

Now if we assume $\lambda = a + bj$ we have:

$$\begin{bmatrix} a - (a + bj) & b \\ -b & a - (a + bj) \end{bmatrix} e = 0 \Leftrightarrow \begin{bmatrix} -bj & b \\ -b & -bj \end{bmatrix} e = 0$$

Since b is not zero:

$$\begin{bmatrix} -j & 1 \\ -1 & -j \end{bmatrix} e = 0 \Leftrightarrow \begin{bmatrix} -j & 1 \\ -1 & -j \end{bmatrix} \begin{bmatrix} x \\ y \end{bmatrix} = 0 \Rightarrow \begin{cases} -jx + y = 0 \\ -x - jy = 0 \end{cases} \Rightarrow$$

$$\begin{cases} -jx + y = 0 \\ -jx - j^2y = 0 \end{cases} \Rightarrow \begin{cases} -jx + y = 0 \\ -jx + y = 0 \end{cases}$$

Thus we have $-jx + y = 0 \Leftrightarrow y = jx$

If we assume that $x=1$ then $y=j$: $e_1 = \begin{bmatrix} 1 & j \end{bmatrix}^T$ and obviously

$$e_2 = \bar{e}_1 = \begin{bmatrix} 1 & -j \end{bmatrix}^T .$$

In that case it can be proved that:

$$e^{\hat{A}t} = e^{\operatorname{Re}(\lambda)t} \begin{bmatrix} \cos(\operatorname{Im}(\lambda)t) & \sin(\operatorname{Im}(\lambda)t) \\ -\sin(\operatorname{Im}(\lambda)t) & \cos(\operatorname{Im}(\lambda)t) \end{bmatrix} .$$

Thus, the state transition matrix of the original system is

$$e^{At} = T \left(e^{Re(\lambda)t} \begin{bmatrix} \cos(Im(\lambda)t) & \sin(Im(\lambda)t) \\ -\sin(Im(\lambda)t) & \cos(Im(\lambda)t) \end{bmatrix} \right) T^{-1}$$

Not assessed material:

$$\Lambda = \begin{bmatrix} a & b \\ -b & a \end{bmatrix}$$

$$\Lambda^2 = \begin{bmatrix} a^2 - b^2 & 2ab \\ -2ab & a^2 - b^2 \end{bmatrix}$$

$$\Lambda^3 = \begin{bmatrix} a(a^2 - b^2) - 2b^2a & 2a^2b + b(a^2 - b^2) \\ -2a^2b - b(a^2 - b^2) & a(a^2 - b^2) - 2b^2a \end{bmatrix}$$

Hence:

$$e^{\Lambda t} = I + \begin{bmatrix} a & b \\ -b & a \end{bmatrix} t + \begin{bmatrix} a^2 - b^2 & 2ab \\ -2ab & a^2 - b^2 \end{bmatrix} \frac{t^2}{2!} +$$

$$\begin{bmatrix} a(a^2 - b^2) - 2b^2a & 2a^2b + b(a^2 - b^2) \\ -2a^2b - b(a^2 - b^2) & a(a^2 - b^2) - 2b^2a \end{bmatrix} \frac{t^3}{3!}$$

Now, I concentrate on the element 1,1:

$$1 + at + (a^2 - b^2) \frac{t^2}{2} + (a(a^2 - b^2) - 2b^2a) \frac{t^3}{6} + \dots \Leftrightarrow$$

$$1 + at + a^2 \frac{t^2}{2} - b^2 \frac{t^2}{2} + (a^3 - ab^2 - 2b^2a) \frac{t^3}{6} + \dots \Leftrightarrow$$

$$1 + at + a^2 \frac{t^2}{2} - b^2 \frac{t^2}{2} + (a^3 - 3b^2a) \frac{t^3}{6} + \dots \Leftrightarrow$$

$$1 + at + a^2 \frac{t^2}{2} - b^2 \frac{t^2}{2} + a^3 \frac{t^3}{6} - 3b^2a \frac{t^3}{6} + \dots \Leftrightarrow$$

$$1 + at + a^2 \frac{t^2}{2} + a^3 \frac{t^3}{6} - b^2 \frac{t^2}{2} - b^2a \frac{t^3}{2} + \dots$$

$$\text{I know that } e^{at} = 1 + at + \frac{(at)^2}{2} + \frac{(at)^3}{3!} + \dots \text{ and } \cos(bt) = 1 - \frac{b^2t^2}{2} + \dots$$

By multiplying them together:

$$e^{at} \cos(bt) = \left(1 + at + \frac{(at)^2}{2} + \frac{(at)^3}{3!} \right) \left(1 - \frac{b^2 t^2}{2} \right) \dots \Leftrightarrow$$

$$1 + at + \frac{(at)^2}{2} + \frac{(at)^3}{3!} - \frac{b^2 t^2}{2} - a \frac{b^2 t^2}{2} t - \frac{(at)^2}{2} \frac{b^2 t^2}{2} - \frac{(at)^3}{3!} \frac{b^2 t^2}{2} \dots \Leftrightarrow$$

$$1 + at + \frac{(at)^2}{2} + \frac{(at)^3}{3!} - \frac{b^2 t^2}{2} - a \frac{b^2 t^2}{2} t \dots$$

Which agrees with the above eqn.

Example 1.7: Find the STM of $\hat{A} = \begin{bmatrix} -2 & 1 \\ -1 & -2 \end{bmatrix}$ and evaluate it at $t=1$.

$$e^{\hat{A}t} = e^{-2t} \begin{bmatrix} \cos(\text{Im}(1)t) & \sin(\text{Im}(1)t) \\ -\sin(\text{Im}(1)t) & \cos(\text{Im}(1)t) \end{bmatrix} \Big|_{t=1} = \begin{bmatrix} 0.0731 & 0.1139 \\ -0.1139 & 0.0731 \end{bmatrix} \quad \blacksquare^8$$

Example 1.8: Using the result of the previous example find the STM of

$A = \begin{bmatrix} 0 & 1 \\ -5 & -4 \end{bmatrix}$ and evaluate it at $t=1$.

$$e^{\hat{A}t} = T e^{\hat{A}t} T^{-1} \Big|_{t=1} = \begin{bmatrix} 0.3009 & 0.1139 \\ -0.5694 & -0.1546 \end{bmatrix} \quad \blacksquare^9$$

⁸ $A = [0 \ 1; -5 \ -4]$; $[x, v] = \text{eigs}(A)$; $T = [\text{real}(x(:,1)) \ \text{imag}(x(:,1))]$; $A_h = \text{inv}(T) * A * T$;
 $e_{\text{Lam}} = \exp(\text{real}(v(1,1))) * [\cos(\text{imag}(v(1,1))) \ \sin(\text{imag}(v(1,1))]; -\sin(\text{imag}(v(1,1))) \ \cos(\text{imag}(v(1,1)))]$
 $\text{expm}(A_h)$

⁹ $e_A = T * e_{\text{Lam}} * \text{inv}(T)$, $\text{expm}(A)$

Obviously if we have an n^{th} order system with only complex eigenvalues the new state matrix is:

$$\hat{A} = T^{-1}AT = \begin{bmatrix} C(a_1, b_1) & 0 & 0 & 0 \\ 0 & C(a_2, b_2) & 0 & 0 \\ 0 & 0 & \ddots & 0 \\ 0 & 0 & 0 & C(a_p, b_p) \end{bmatrix},$$

with $C(a_i, b_i) = \begin{bmatrix} a_i & b_i \\ -b_i & a_i \end{bmatrix}$ and

$$T = \begin{bmatrix} \text{Re}(e_1) & \text{Im}(e_1) & \cdots & \text{Re}(e_p) & \text{Im}(e_p) \end{bmatrix}, p=n/2.$$

4.3 Case 3: Repeated Real Eigenvalues

In this case we have only one LI eigenvector and to solve the system we have seen in EEE8013 that we can find another LI (generalised) eigenvector by solving $e = (A - \lambda I)b$. Hence $T = \begin{bmatrix} e & b \end{bmatrix}$ and we have as before:

$$AT = A \begin{bmatrix} e & b \end{bmatrix} = \begin{bmatrix} Ae & Ab \end{bmatrix} = \begin{bmatrix} \lambda e & Ab \end{bmatrix}$$

Now from $e = (A - \lambda I)b \Leftrightarrow e + \lambda b = Ab$

$$\text{So } AT = \begin{bmatrix} \lambda e & e + \lambda b \end{bmatrix} = \begin{bmatrix} e & b \end{bmatrix} \begin{bmatrix} \lambda & 1 \\ 0 & \lambda \end{bmatrix} = T\hat{A}$$

Hence now the result is $\hat{A} = \begin{bmatrix} \lambda & 1 \\ 0 & \lambda \end{bmatrix}$.

Note: If we have 2 LI eigenvectors for the same eigenvalue then the new

state matrix is as before: $\hat{A} = \begin{bmatrix} \lambda & 0 \\ 0 & \lambda \end{bmatrix}$

Example 1.9: Find the canonical form of $A = \begin{bmatrix} 3 & -18 \\ 2 & -9 \end{bmatrix}$:

$$\hat{A} = TAT^{-1} = \begin{bmatrix} 3 & 1 \\ 0 & 3 \end{bmatrix} \quad \blacksquare^{10}$$

If we have an n^{th} order system with one eigenvalue and one LI eigenvector:

$$\hat{A} = T^{-1}AT = \begin{bmatrix} \lambda & 1 & 0 & 0 \\ 0 & \lambda & 1 & 0 \\ 0 & 0 & \ddots & 1 \\ 0 & 0 & 0 & \lambda \end{bmatrix}.$$

On the other hand if we have 2 or 3 LI eigenvectors:

$$\hat{A} = \begin{bmatrix} \lambda & 0 & 0 & 0 \\ 0 & \lambda & 1 & 0 \\ 0 & 0 & \ddots & 1 \\ 0 & 0 & 0 & \lambda \end{bmatrix}, \hat{A} = \begin{bmatrix} \lambda & 0 & 0 & 0 & 0 \\ 0 & \lambda & 0 & 0 & 0 \\ \vdots & 0 & \ddots & 1 & 0 \\ & & \ddots & \lambda & \ddots \\ 0 & & & 0 & \lambda \end{bmatrix}$$

¹⁰ A=[3 -18;2 -9]; e1=[3, 1]';syms b1 b2;eqn=(A+3*eye(2))*[b1; b2]-[3;1]; s=solve(eqn); e2=[s.b1; s.b2]; T=[e1 e2]; inv(T)*A*T

The new eigenvectors of the 2x2 system are: $\left(\begin{bmatrix} \lambda & 1 \\ 0 & \lambda \end{bmatrix} - \lambda I \right) e = 0$. Which

can be written as: $\begin{bmatrix} 0 & 1 \\ 0 & 0 \end{bmatrix} e = 0 \Leftrightarrow y = 0, x = \text{anything} = 1$ and hence the

only eigenvector is $e = \begin{bmatrix} 1 & 0 \end{bmatrix}$.

The corresponding exponential matrix is:

$$\begin{aligned} e^{\hat{A}t} &= I + \hat{A}t + \frac{\hat{A}^2 t^2}{2!} + \dots = I + \begin{bmatrix} \lambda & 1 \\ 0 & \lambda \end{bmatrix} t + \begin{bmatrix} \lambda & 1 \\ 0 & \lambda \end{bmatrix} \begin{bmatrix} \lambda & 1 \\ 0 & \lambda \end{bmatrix} \frac{t^2}{2!} + \dots \\ &= I + \begin{bmatrix} \lambda & 1 \\ 0 & \lambda \end{bmatrix} t + \begin{bmatrix} \lambda^2 & 2\lambda \\ 0 & \lambda^2 \end{bmatrix} \frac{t^2}{2!} + \dots = \begin{bmatrix} 1 + \lambda t + \lambda^2 \frac{t^2}{2!} \dots & t + 2\lambda \frac{t^2}{2!} + 3\lambda^2 \frac{t^3}{3!} \\ 0 & 1 + \lambda t + \lambda^2 \frac{t^2}{2!} \dots \end{bmatrix} \\ &= \begin{bmatrix} 1 + \lambda t + \lambda^2 \frac{t^2}{2!} \dots & t \left(1 + \lambda t + \lambda^2 \frac{t^2}{2!} \right) \\ 0 & 1 + \lambda t + \lambda^2 \frac{t^2}{2!} \dots \end{bmatrix} = \begin{bmatrix} e^{\lambda t} & t e^{\lambda t} \\ 0 & e^{\lambda t} \end{bmatrix} \end{aligned}$$

and hence $e^{At} = T \begin{bmatrix} e^{\lambda t} & t e^{\lambda t} \\ 0 & e^{\lambda t} \end{bmatrix} T^{-1}$

Example 1.10: Find the STM of $A = \begin{bmatrix} 3 & 1 \\ 0 & 3 \end{bmatrix}$ and evaluate it at $t=1$:

$$e^{\hat{A}t} = \begin{bmatrix} e^{\lambda t} & t e^{\lambda t} \\ 0 & e^{\lambda t} \end{bmatrix} = \begin{bmatrix} e^{-3t} & t e^{-3t} \\ 0 & e^{-3t} \end{bmatrix} \Big|_{t=1} = \begin{bmatrix} 0.0498 & 0.0498 \\ 0 & 0.0498 \end{bmatrix} \quad \blacksquare^{11}$$

¹¹ syms t, e_Lam=[exp(-3*t) exp(-3*t)*t;0 exp(-3*t)], expm([-3 1;0 -3]*t), eval(subs(e_Lam,t,1))

Example 1.11: Using the result of the previous example, find the STM of

$$A = \begin{bmatrix} 3 & -18 \\ 2 & -9 \end{bmatrix}; e^{At} = Te^{\hat{A}t}T^{-1} = \begin{bmatrix} 0.3485 & -0.8962 \\ 0.0996 & -0.2489 \end{bmatrix} \quad \blacksquare^{12}$$

4.3 Case 4: Repeated Complex Eigenvalues

This case is similar to the previous ones (combined) but the analysis is more complicated so we will just give the result. If we have an 4th order system with a repeated complex eigenvalue $\lambda = a + bj$ then the new state matrix is:

$$\hat{A} = \begin{bmatrix} a & -b & 1 & 0 \\ b & a & 0 & 1 \\ 0 & 0 & a & -b \\ 0 & 0 & b & a \end{bmatrix}$$

and in general: $\hat{A} = \begin{bmatrix} C(a,b) & I_2 & 0 & 0 & \dots & 0 \\ 0 & C(a,b) & I_2 & & & \\ \vdots & 0 & \ddots & \ddots & & \\ \vdots & & & & & I_2 \\ 0 & 0 & \dots & 0 & C(a,b) \end{bmatrix}$.

¹² $T*\text{expm}([-3 \ 1; 0 \ -3]*t)*\text{inv}(T)$, $\text{expm}(A)$

5. Exercises

Determine the normal form, the STM of the normal form and through that the STM of the following systems:

$$1. \quad x' = \begin{bmatrix} -4 & 1 \\ -6 & 1 \end{bmatrix} x$$

$$2. \quad x' = \begin{bmatrix} 0.5 & -0.5 \\ 4.5 & -2.5 \end{bmatrix} x$$

$$3. \quad x' = \begin{bmatrix} 2.5 & -2.5 \\ 12.5 & -8.5 \end{bmatrix} x$$

6. Matlab Based Exercises for EEE8086

1. Use Matlab to solve the problems of section 5.
2. Repeat the same exercise for the following systems at $t=1$:

$$a. \quad x' = \begin{bmatrix} -2 & -4 & 2 \\ -2 & 1 & 2 \\ 4 & 2 & 5 \end{bmatrix} x$$

$$b. \quad x' = \begin{bmatrix} 3 & 2 & 4 \\ 2 & 0 & 2 \\ 4 & 2 & 3 \end{bmatrix} x$$

$$c. \quad x' = \begin{bmatrix} 1 & 1 & 1 \\ 2 & 1 & -1 \\ -3 & 2 & 4 \end{bmatrix} x$$

$$d. \quad x' = \begin{bmatrix} 1 & 1 & 1 \\ 2 & 1 & -1 \\ -3 & 2 & 4 \end{bmatrix} x$$

$$e. \quad x' = \begin{bmatrix} -3 & 0 & 2 \\ 1 & -1 & 0 \\ -2 & -1 & 0 \end{bmatrix} x$$